

**COUNTY OF ONONDAGA**  
**DIVISION OF PURCHASE**  
 13<sup>TH</sup> FLOOR  
 421 MONTGOMERY STREET  
 SYRACUSE NEW YORK 13202

**BLANKET PRICE AGREEMENT**

<b>NOTICE OF CONTRACT AWARD</b>	
<b>COMMODITY/SERVICE:</b> Trucks (Heavy Duty Class 8) Cab-Chassis Type W/Dump Bodies, Snow Plows & Associated Options/Accessories	
<b>CONTRACT PERIOD:</b> June 24, 2018 through June 23, 2023	<b>BID OPENED:</b> June 7, 2018.
<b>BID REF. #:</b> 8996	<b>PRICING :</b> Blanket Price Agreement
<b>DATE ISSUED:</b> 7/20/2018	<b>INQUIRIES TO:</b> Cory Larrabee E-mail <a href="mailto:corylarrabee@ongov.net">corylarrabee@ongov.net</a>

**VENDOR NAME & ADDRESS**

**PHONE NO. AND CONTACT**

TRACEY ROAD  
 6803 MANLIUS CENTER ROAD  
 EAST SYRACUSE NY 13057

JAY BARNWELL 315-435-1471  
[jbarnwell@traceyroad.com](mailto:jbarnwell@traceyroad.com)

KENWORTH NORTHEAST GROUP  
 100 COMMERCE DR  
 BUFFALO NY 14218

DOUG HUGHES  
[dhughes@kenworthne.com](mailto:dhughes@kenworthne.com)

BEAM MACK  
 6260 EAST MOLLOY ROAD

GREG ANGWIN  
[grega@beammack.com](mailto:grega@beammack.com)

DATE

8/23/2021

QUOTE INFORMATION

CONW2021000450A544

GRANITE 64FR

Qty: 1

BEAM MACK SALES & SERVICE, INC. 3050 LAKE ROAD HORSEHEADS NY 14845

PREPARED BY

BEAM MACK SALES &  
SERVICE, INC.

3050 LAKE ROAD

HORSEHEADS

NY 14845

BEAM MACK SALES & SERVICE, INC. 3050 LAKE ROAD HORSEHEADS NY 14845

RECEIVED FROM

ULYSSES HIGHWAY  
DEPARTMENT

3888 COLEGROVE RD

JACKSONVILLE

NY 14854

# PROPOSAL

2023 MODEL YEAR 3RD QUARTER OF 2022 PRODUCTION

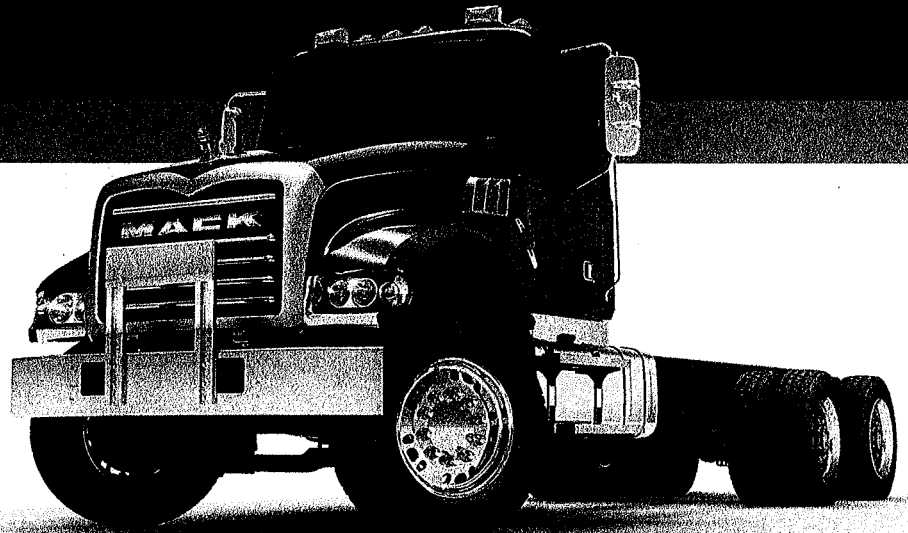



# TECHNICAL SPECIFICATION

## GRANITE 64FR

APPLICATION PACKAGES	DESCRIPTION	WEIGHT (LB)		LIST PRICE	
		FRONT	REAR		
MPK03K	CHASSIS CONFIGURATION PACKAGE	ONEBOX EATS, LH BATTERY BOX, 8.7 GALLON (33L) SLEEVED DEF, SINGLE 26" LH FUEL TANK	0	0	0

CUSTOMER/VEHICLE INFO	DESCRIPTION	WEIGHT (LB)		LIST PRICE	
		FRONT	REAR		
S 002EF2	CHASSIS (BASE MODEL)	GRANITE 64FR	4,844	1,813	0
S 99X93X	ASSEMBLY PLANT	Made in Macungie, PA USA	0	0	0
MP2001	CUSTOMER FLEET SIZE	DEALER FLEET WITH LESS THAN 25 VEHICLES IN OWN FLEET OF ANY VEHICLE BRAND	0	0	0
013002	TYPE OF SERVICE	MUNICIPAL	0	0	0
S M98018	WARRANTY REGISTRATION LOCATION	US - WARRANTY REGISTRATION LOCATION	0	0	0
MBT02T	EMISSION WARRANTY CERTIFICATION	CARB + EPA for Mack MP7 / MP8 Diesel	0	0	0
S 5050B5	INITIAL REGISTRATION LOCATION	USA REGISTRATION	0	0	0
S 534014	LANGUAGE-PUBS/DECAL/SIGNS	ENGLISH	0	0	0
S DHX10X	ROAD CONDITION	WELL MAINTAINED SURFACED ROADS >95% DRIVING DISTANCE	0	0	0
0050M5	VEHICLE USE & BODY/TRAILER TYPE	SNOW PLOW FRONT MOUNTED	0	0	0
2KEC1X	TRAILER TYPE	FIXED DRAWBAR TRAILER AND CENTERED AXLES	0	0	0
DKXLAX	GROSS COMBINATION WEIGHT (CA in PC29 only)	110,000 LB (50 TONNES) GROSS COMBINATION WEIGHT	0	0	0
S 70BB1X	BRAKE REGULATION	BRAKE REGULATION, STOPPING DISTANCE 94M (310FT)	0	0	0
QCXB1X	TOPOGRAPHY	GRADES <6% GREATER THAN 98% OF DRIVING DISTANCE MAX GRADE 16%	0	0	0
S E1BD1X	AMBIENT TEMP UPPER LIMIT (GTA)	AMBIENT TEMPERATURE HOT. WARMER THAN 104 F (40 C) ALLOWED UP TO 25 HOURS PER YEAR	0	0	0
S 032A89	TERRAIN GRADE	ON-OFF HIGHWAY, STARTING GRADES<18%	0	0	0
033A30	LOADING SURFACE	GRAVEL LOADING AND / OR UNLOADING SURFACE	0	0	0
0342A2	VEHICLE VOCATION	CONSTRUCTION SERVICE	0	0	0

# TECHNICAL SPECIFICATION *(cont.)*



ENGINE/TRANSMISSIONS	DESCRIPTION	WEIGHT (LB)		LIST PRICE	
		FRONT	REAR		
1004F0	<b>ENGINE PACKAGE, COMBUSTION</b>	MP8-505C MACK 505HP @ 1500-1700 RPM (PEAK) 2100 RPM (GOV) 1850 LB-FT, US'21	2,165	541	5,642
S 3GCB1X	<b>GHG APPLICATION, VEHICLE</b>	GREEN HOUSE GAS VOCATIONAL APPLICATION	0	0	0
136176	<b>TRANSMISSION</b>	MACK TMD14AFO-HD mDRIVE HD 14 SP, ULTRA-LOW CREEPER/ MULTI-SPEED REVERSE (OVERDRIVE)	578	192	604
S V4EZ9X	<b>GEARBOX 12TH GEAR LOCK-OUT</b>	WITHOUT 12TH GEARBOX GEAR LOCK-OUT	0	0	0

EXHAUST/EMISSIONS	DESCRIPTION	WEIGHT (LB)		LIST PRICE	
		FRONT	REAR		
CIRAA4	<b>CARB 2008 IDLE REGULATION</b>	IDLE EMISSION CERTIFICATION, CARB (WITH DECAL LOCATED ON LOWER LH CORNER / DRIVER DOOR	0	0	0
S DPF04F	<b>DPF DIESEL PARTICULATE FILTER</b>	CLEARTECH ONE BOX E.A.T.S. RH SIDE UNDER CAB US17 / US21	0	0	0
MCF08F	<b>CHASSIS MOUNTED EMISSIONS FINISH</b>	W/O DEF COVER & STAINLESS STEEL DPF COVER	0	0	257
DF10P1	<b>DEF TANK</b>	8.7 GALLON (33 L) 26" LEFT SIDE FUEL TANK MTD	84	45	0
130AD7	<b>EXHAUST</b>	SINGLE VERTICAL RIGHT SIDE CAB MOUNTED, LOWER VENTURI DIFFUSER, TURNED END	-35	-17	377
KRXAPX	<b>EXHAUST STACK HEIGHT</b>	9' 6" FROM GROUND	0	0	0
Q0AC1X	<b>EXHAUST SYSTEM MATERIAL FINISH</b>	SINGLE, BRIGHT FINISH HEAT SHIELD, STACK AND SCR COVER (IF EQUIPPED)	0	0	97
78ADAX	<b>EMISSION ON BOARD DIAG CONTROL</b>	EMISSION OBD, DISPLAY ONLY, USA2022	0	0	0

ENGINE EQUIPMENT	DESCRIPTION	WEIGHT (LB)		LIST PRICE	
		FRONT	REAR		
125035	<b>AIR CLEANER</b>	UNDER HOOD SINGLE ELEMENT DRY TYPE W/AIR CONTROLLED INSIDE-OUTSIDE AIR INTAKE&DASH MTD AIR RESTRICTI	0	0	456
1VAADX	<b>AIR INTAKE SOURCE</b>	INSIDE/OUTSIDE AIR INTAKE W/ IN-CAB CONTROL FOR SNOWPLOW	20	0	0
S 121AA5	<b>BUG SCREEN</b>	BLACK ALUMINUM BUG SCREEN MOUNTED BEHIND GRILLE, WITHOUT WINTER FRONT COVER	0	0	0
S 1130L3	<b>AIR COMPRESSOR/DRYER</b>	WABCO AIR DR SS-HP AIR DRYER W/ WABCO 318 (18.7 CFM) AIR COMPRESSOR	0	0	0
S KOXA1X	<b>AIR DRYER POSITION (CA)</b>	AIR DRYER POSITION STANDARD	0	0	0
132AA8	<b>ALTERNATOR</b>	LEECE NEVILLE 12V 160A BRUSHLESS	31	0	158
316AA7	<b>BATTERIES</b>	(3) MACK 12V 1000/3000 CCA THREADED STUD TYPE	16	7	99
S 393AA2	<b>BATTERY BOX - MOUNTING</b>	LH RAIL UNDER CAB FORWARD OF FUEL TANK (3 BATTERY MAX)	-8	-4	0
L5XL1X	<b>BATTERY BOX COVER</b>	MOLDED PLASTIC W/SPLASH GUARD	3	0	44
318AA3	<b>BATTERY DISCONNECT SWITCH</b>	FLAMING RIVER BIG SWITCH WIRED TO POSITIVE SIDE	3	0	146
S NCXA5X	<b>STARTER MOTOR</b>	12 VOLT DELCO 39MT-MXT	31	0	0
110AA6	<b>ENGINE BRAKE</b>	MACK MP8 POWERLEASH	0	0	0
S JMXB1X	<b>ENGINE BRAKE LIGHTING (CA)</b>	VEHICLE AND TRAILER (IF APPLICABLE) STOP LAMPS ACTIVATE UPON SERVICE BRAKE APPLICATION ONLY(3899000)	0	0	0
S 118AB8	<b>FAN DRIVE</b>	BEHR FAN AND ELECTRONIC MODULATING VISCOUS FAN DRIVE	0	0	0

TECHNICAL SPECIFICATION (cont.)



ENGINE EQUIPMENT	DESCRIPTION	WEIGHT (LB)		LIST PRICE	
		FRONT	REAR		
119AG9	COOLANT PROTECTION	ETHYLENE GLYCOL EXTENDED LIFE COOLANT (50/50 MIX DYED RED) TO -34DEG, W/ LONG LIFE FILTER	0	0	72
H9XK1X	RADIATOR TYPE	RADIATOR, CORE AREA W/O FEPTO 1345sq in (86sq dm), CORE AREA W/ FEPTO 1296sq in (83sq dm)	0	0	0
124AA2	HOSES - RADIATOR/HEATER	SILICONE RADIATOR AND HEATER HOSES	0	0	247
293AA4	FUEL-WATER SEPARATOR	DAVCO 382, (FLUID HTD) W/12V PREHEAT W/VENDOR PRIMARY	3	5	677
S MBXA1X	PRIMARY FUEL FILTER POSITION (CA)	STANDARD FUEL FILTER POSITION	0	0	0
MCA04B	ENGINE HEATERS	GRID HEATER + 120v 1500w BLOCK HEATER ONLY (120V-15A PLUG)	0	0	177
5NXA1X	ENGINE BLOCK HEATER	120V 1500W ENGINE BLOCK HEATER	5	0	0
NDXA1X	ENGINE STARTING AID	ELECTRIC PREHEATER	7	0	0
QHXABX	OIL PAN	CORROSION RESISTANT OIL PAN	0	0	190
36AD1X	TETHER DEV PKG, CAPS & COVERS	CAP RETAINER FOR OIL FILL & RADIATOR OVERFLOW TANK, BATTERY BOX, AND TOOL BOX (IF FURNISHED)	0	0	35
S 2YBZ1X	ENGINE STOP, EMERGENCY (CA In PC29 only)	WITHOUT ENGINE STOP, EMERGENCY	0	0	0

CLUTCH/TRANS EQUIPMENT	DESCRIPTION	WEIGHT (LB)		LIST PRICE	
		FRONT	REAR		
S 49200B	GEAR SHIFTER	MACK mDRIVE-PREMIUM SHIFTER	0	0	0
S 133AC7	CLUTCH	ZF/SACHS SINGLE PLATE 17" (430MM) ORGANIC MATERIAL	0	0	0
S MCB05B	CLUTCH ACTUATION SYSTEM & PEDAL PAD	WITHOUT CLUTCH CABLE SYSTEM	0	0	0
S 195045	DRIVELINE - MAIN	MERITOR RPL35, WITH CROSS SERRATED YOKE (PROPS-XL)	20	45	0
S 204014	DRIVELINE - INTERAXLE	MERITOR RPL25	0	36	0
S 76AXAX	PROPELLR SHAFT MAIN, UNVSL JNT	UNIVERSAL JOINT CROSS SERRATED YOKE	0	0	0
S 8WAAAX	PROP SHAFT INTERAXL UNIV JOINT	HALF-ROUND UNIVERSAL JOINT	0	0	0
S 4LDA1X	TRANSMISSION OUTPUT TORQUE	TRANSMISSION OUTPUT TORQUE BASIC	0	0	0
S RCXB1X	BELL HOUSING	ALUMINUM	0	0	0
S 7RXD1X	LUBRICANTS, TRANSMISSION	75W - 90 (SYNTHETIC LUBRICANT)	0	0	0
S 139049	TRANSMISSION OIL COOLER	MACK mDRIVE TRANSMISSION OIL COOLER MOUNTED LH SIDE OIL TO WATER COOLER	0	0	0

FRONT AXLE EQUIPMENT	DESCRIPTION	WEIGHT (LB)		LIST PRICE	
		FRONT	REAR		
240AA5	FRONT AXLE	23000# (10400 KG) MACK FXL23 WIDE PIVOT CENTER STRAIGHT SPINDLE/UNITIZED BEARINGS	428	0	780
244124	SPRINGS - FRONT	MACK MULTILEAF 23000# (10400 KG) GROUND LOAD RATING, RIGHT SPRING BIAS	197	0	217
2410L1	FRONT AXLE BRAKES	MERITOR EX+ AIR DISC BRAKES 430MM (17") H-TYPE	25	0	788
U3XD1X	BRAKE, FRONT	FRONT BRAKE DISC LIGHTWEIGHT	23	0	0
UDXA1X	FRONT AXLE BRAKE DUST SHIELD	DUST SHIELDS FOR FRONT AXLE	5	0	28
U0AF1X	FRONT BRAKE ADJ. MANUFACTURE	AUTOMATIC FOR AIR DISC BRAKES	0	0	0

TECHNICAL SPECIFICATION (cont.)



FRONT AXLE EQUIPMENT		DESCRIPTION	WEIGHT (LB)		LIST PRICE	
			FRONT	REAR		
	V7AF1X	FRONT BRAKE CHAMBER MFG.	FRONT BRAKE CHAMBER MANUFACTURER, WABCO	0	0	0
	YHXB1X	FRONT SPRING BIAS	FRONT SPRING BIAS, RIGHT (STIFFER SPRING ON RH-SIDE)	16	0	0
	0KXG1X	HUB MATERIAL, FRONT	BASIC HUB UNITIZED IRON, FRONT	157	0	61
S	1KAA1X	SHOCK ABSORBER, FRONT	DOUBLE ACTING TYPE	0	0	0
	245AB0	STEERING	SHEPPARD SD110 + HD94	206	0	858
S	7VXC1X	LUBRICANTS, FRONT AXLE	PETROLEUM/SYNTHETIC (50/50) OIL FRONT AXLE	0	0	0

REAR AXLE EQUIPMENT		DESCRIPTION	WEIGHT (LB)		LIST PRICE	
			FRONT	REAR		
	268AA9	REAR AXLES - TANDEM	46000# (20900kg) MACK S462R CAST DUCTILE HOUSING	0	1,614	2,534
S	6MAA1X	REAR AXLE CASING WIDTH	W/O WIDE TRACK AXLE	0	0	0
S	018AA6	CARRIER - REAR AXLE	CRDP150/151 AVAILABLE WITH OPTIONAL DRIVER CONTROLLED INTERWHEEL DIFFERENTIAL LOCKS, SEE 254 SYMBOL	0	0	0
	TAXGHX	REAR AXLE RATIO	3.98 RATIO	0	0	0
	186AC7	REAR SUSPENSION - TANDEM	MACK mRIDE 46 PARABOLIC 3-LEAF, 46,000 lb	0	1,537	1,263
	GWXDGX	BOGIE SPREAD, REAR	54" AXLE SPACING (BOGIE WHEELBASE)	0	89	0
	YVXA1X	REAR SHOCK ABSORBER	REAR SHOCK ABSORBER	0	27	0
	XYXZ1X	TRANSVERSE TORQUE RODS, R SUSP	WITHOUT TRANSVERSE TORQUE RODS	0	-66	0
S	237037	AUX. SPRING BRAKE QTY	AUX SPRING BRAKE QTY, 4 CHAMBERS	0	0	0
	UGXA1X	AUX. PARKING BRAKE CHAMBERS	AUXILIARY PARK, TWO EXTRA PARKING BRAKE CHAMBERS	0	20	0
	253AB3	BRAKES - REAR	MERITOR EX+ AIR DISC BRAKES, 430MM (17") - H TYPE (Total for QTY = 2)	0	75	3,488
	U4XD1X	BRAKE, DRIVE, REAR	BRAKE DRIVE, REAR, DISC LIGHTWEIGHT	0	0	0
	U1AG1X	REAR BRAKE ADJ MANUFACTURE	AUTOMATIC SLACK ADJUSTERS FOR REAR AIR DISC BRAKES (Total for QTY = 2)	0	0	0
	UEXA1X	DRIVE AXLE BRAKE DUST SHIELD	DUST SHIELDS FOR REAR AXLE	0	12	50
	V1AE3X	REAR BRAKE CHAMBER SIZE	REAR SPRING BRAKE CHAMBERS 24/24 TYPE	0	0	0
	N5FBFX	BRAKE ORI REAR-MOST DRIVE AXLE	DISC BRAKE CHAMBER ORIENTATION: Middle Mount - Forward of Axle - Chamber Inward	0	0	0
	300AF0	REAR BRAKE CHAMBER	WABCO BRAKE CHAMBERS VENDOR (Total for QTY = 2)	0	0	-128
	0LXE1X	HUB MATERIAL, DRIVE	CONMET IRON HUBS W/PRESET BEARINGS & SEALS	0	309	0
S	3LAC1X	POWER DIVIDER LOCKOUT	POWER DIVIDER LOCKOUT, W/BUZZER & LIGHT	0	40	0
S	7WXA1X	LUBRICANTS, REAR AXLE(s)	FACTORY OPTION LUBE - REAR AXLE 80W-90	0	0	0
	254AB5	TRACTION DIFFERENTIAL	DRIVER CONTROLLED INTER WHEEL DIFFERENTIAL LOCK ALL RR AXLES, MANUAL AIR VALVE W/WARNING LIGHT.	0	18	1,459
S	698078	ANTILOCK BRAKE SYSTEM	BENDIX WITH TRACTION CONTROL 4S4M	0	0	0
S	URXD1X	BRAKE VALVE VERSION	BENDIX SWITCHES AND VALVES WHERE POSSIBLE	0	0	0
S	H9CA1X	TRACTION CONTROL DISABLE (CA in PC29 only)	AUTOMATIC TRACTION CONTROL (ATC) FULL DISABLE SWITCH	0	0	0
S	3ZAA1X	SPRING BRAKE INVERSION VALVE	TRACTOR SPRING BRAKE INVERSION VALVE	5	0	0

TECHNICAL SPECIFICATION (cont.)



			WEIGHT (LB)		LIST PRICE
FRAME EQUIPMENT/FUEL TANKS	DESCRIPTION	FRONT	REAR		
271230	WHEELBASE	230"	192	192	157
374087	AF (OVERHANG)	87"	-19	408	0
MCE0FE	FRAME RAILS & LINERS	11.1 x 105 x 300mm - (0.437" x 4.13" x 11.81"); RBM 3,160,000 LB-IN	0	0	1,202
5CAZ1X	FRONT FRAME EXT. (BOLTED ON)	W/O FRONT FRAME EXTENSION	0	0	-202
A0XF3X	FRONT FRAME LENGTH	BUMPER POSITION EXTENDED 20" (SNOW)	148	-15	1,569
281AA6	CROSSMEMBERS	BOC AND INTERMEDIATE CROSSMEMBERS, HD I-BEAM	27	27	166
AXXA3X	AUX CROSSM. IN REAR OVERHANG	ONE STEEL I-BEAM	-37	137	190
Q5AG1X	REAR CROSSMEMBER OPTIONS	I-BEAM REAR CROSSMEMBER	-22	82	190
S X6XA1X	REAR FRAME TREATMENT	WITHOUT TAPERED FRAME RAIL ENDS	0	0	0
S 4DXM9X	FRONT BUMPER	EXTENDED-SWEPT BACK-STEEL	0	0	0
S 4ZAAAX	CROSSMEMBER, BOGIE TYPE	BASIC SOLUTION TRUNNION BRACKET, STD HEIGHT	0	0	0
S 4EXG1X	TOWING DEVICE, FRONT	HOOKS	0	0	0
6PXD1X	TOWING DEVICE, REAR	HOOKS - FRAME MOUNTED	-6	27	33
S 2RAA1X	FUEL LEVEL SENDER UNIT, LIQUID	BASIC FUEL LEVEL SENDER MOUNTED ON L.H TANK	0	0	0
288AF3	FUEL TANK - LH	72 GALLON (275 L) 26" ALUMINUM, SLEEVED D-SHAPED	153	75	308
S 290AA1	FUEL TANK - RH	W/O RH FUEL TANK	0	0	0
S JHXB1X	FUEL HOSES, LIQUID	BRAIDED HOSE	5	3	0
S 8520C2	FUEL FILLER NECK OPTIONS	WITHOUT FILLER NECK SCREEN, WITH NON-LOCKABLE FUEL TANK CAP	0	0	0
12AA1X	FUEL LINE OPTIONS, LIQUID	W/O FUEL LINE OPTION	0	0	0
Q2ATCX	CAB INSTEP VERSION	RH/LH 3 STEP CAB ACCESS W/ TOP OF LOWEST STEP NOT MORE THAN 18" FROM GROUND	23	9	66
223AA3	STEPS (BRIGHT) - FUEL TANK	STANDARD FINISH STEPS AND BRIGHT FINISH STRAPS	0	0	0

			WEIGHT (LB)		LIST PRICE
AIR/BRAKE	DESCRIPTION	FRONT	REAR		
S UWXC1X	AIRTANK DRAIN VALVE	MANUAL (PETCOCK) DRAIN VALVES ON ALL TANKS	0	0	0
S U2XB1X	AIRTANK MATERIAL	STEEL AIR TANK PAINTED CHASSIS COLOR	0	0	0
141AB0	RELOCATE AIR RESERVOIRS	RELOCATE ALL AIR RESERVOIRS INFRAME	0	0	74
VSBX1X	AUXILLIARY AIRTANK	AUXILIARY AIR TANK CAPACITY FOR (1) EXTRA LIFT AXLE	20	16	387
1JAABX	PARKING BRAKE VALVE	TWO (2) VALVE DUAL BRAKE SYSTEM - TRAILER SUPPLY AND TRACTOR-TRAILER PARK	0	0	62

			WEIGHT (LB)		LIST PRICE
ELECTRICAL	DESCRIPTION	FRONT	REAR		
5RXA6X	BACK-UP ALARM	ECCO BACK-UP ALARM 575 CONSTANT SOUND LEVEL 107 dB	0	3	111
EAXTAX	DASH MOUNTED SWITCHES	8 SW;STRB;CHAIN;SNDR;ALTRNG; LOAD;ROTATING LTS;TAIL LK/UNLK & SPARE BATT WIRED THRU BB BOC (8 EXTRA SWITCHES FOR BODY INSTALLER)	0	0	272

ELECTRICAL	DESCRIPTION	WEIGHT (LB)		LIST PRICE	
		FRONT	REAR		
NGXP1X	AUX. FOG LAMP	DASH CONTROL & WIRING, W/HOLESIZE TO ACCOMMODATE LOCAL INSTALL OF RND/RECT AUX FOG OR DRIVING OR ANY FRONT AUX LIGHT	3	0	18
S 3120A2	ROOF & SIDE MARKER LIGHTS	(5) TRUCKLITE CHROME BULLET ROOF MARKER & STANDARD MARKER / DIRECTIONAL SIGNAL	0	0	0
NJXA3X	AUXILIARY LAMPS (CA in PC29 only)	DASH CTRL/PWR SUPPLY/LOCAL INST PLOW LAMPS W/LEAD FURN@ GRILL W/2W/3W WEATHER PACK CON	0	0	99
S LSXJ7X	DAYTIME RUNNING LIGHTS	W/OVERRIDE SWITCH, PARK BRAKE & ENGINE RUNNING ACTIVATED	0	0	0
S X2AA1X	DRL OVERRIDE SPEED THRESHOLD	DRL OVERRIDE SPEED THRESHOLD 8 KMPH (5 MPH)	0	0	0
S NEXC1X	TAIL LAMPS	INCANDESCENT TAIL LAMPS	0	7	0
05AGAX	WORK LIGHTS - CHASSIS MOUNTED	RH/LH LED WORK LIGHT (STEPS & GROUND) ON BOTH SIDES TRUCK SUPERBRIGHT LED	3	0	170

TRAILER CONNECTIONS	DESCRIPTION	WEIGHT (LB)		LIST PRICE	
		FRONT	REAR		
WGXC1X	TRAILER BRAKE VALVE	HAND CONTROL VALVE FOR TRAILER OR REAR SERVICE BRAKES - DUAL FUNCTION	7	0	78
301031	HAND CONTROL VALVE	HAND CONTROL VALVE FOR TRAILER OR REAR SERVICE BRAKES - DUAL FUNCTION	7	0	0
WHXQ2X	TRAILER CONNECTION POSITION (CA in PC29 only)	TRAILER AIR BRAKE CONNECTIONS, END OF FRAME FOR LOCALLY INSTALLED HITCH	23	23	478
321031	TRAILER ELECTRICAL RECEPT	SINGLE 7 PINS STD SAE TYPE, END OF FRAME	0	0	160
CA 3220O2	TRAILER HOOKUP LIGHT	WORKING LAMP PREP KIT, SWITCH & CABLE HARNESS, ROUTE TO CENTER CAB OF BACK TO THE HIGHEST POINT FOR ROOF LIGHT	0	0	47
S 3SAZ1X	TRAILER CONNECTORS HOLDER	OMIT TRAILER CONNECTORS HOLDER ON BOC	3	0	0

PTO	DESCRIPTION	WEIGHT (LB)		LIST PRICE	
		FRONT	REAR		
S 189AK9	PTO - REAR MOUNTED	W/O TRANSMISSION MOUNTED PTO - (mDRIVE ONLY)	0	0	0
TYXZ1X	POWER TAKE OFF CONTROL	WITHOUT TRANSMISSION PTO CONTROL	0	0	-235
416AA3	REAR ENGINE PTO	W/SPLINED SHAFT GROOVE (FEMALE)DIN 5462, FOR INSTALL OF HYD.PUMP.(PLATE ONLY)	0	0	2,741
S 2WAZ1X	PTO TRANS NEUTRAL CONTRL CHECK	W/O NEUTRAL CONTROL	0	0	0
S B83083	BODY BUILDER INTERFACE	BODY LINK III W/CAB PASS-THRU	5	5	0

SPECIALTY EQUIPMENT	DESCRIPTION	WEIGHT (LB)		LIST PRICE	
		FRONT	REAR		
S MCQ01Q	LANE SUPPORT SYSTEM (LSS)	WITHOUT LANE SUPPORT SYSTEM	0	0	0
S 2PEZ1X	DATA CAPTURE	WITHOUT DATA CAPTURE	0	0	0
S 1PAZ1X	CAMERA, SURVEILLANCE	WITHOUT CAMERA	0	0	0



**TECHNICAL SPECIFICATION (cont.)**

			WEIGHT (LB)		LIST PRICE	
CAB INTERIOR (A THRU G)			FRONT	REAR		
		DESCRIPTION				
S	198048	GAUGES - UNIT OF MEASURE	U.S. UNITS (PREDOMINANT)	0	0	0
	CCXE1X	GAUGE - PACKAGE, SECONDARY	2ND GA PKG W/ENG OIL TEMP, TRANS OIL TEMP, PYRO, AIR RESTRICT	0	0	128
	E1AAAX	GAUGE - REAR AXLE OIL TEMP	REAR AXLE OIL TEMP GAUGE IN DID (DRIVER INFORMATION DISPLAY)	0	0	0
	PFXB1X	GAUGE - AMBIENT TEMPERATURE	AMBIENT & ROAD TEMPERATURE GAUGE, DIGITAL DISPLAY IN MIRROR TO PING ROAD SURFACE TEMP	0	0	978
S	173AA5	AIR CONDITIONING/HEATER	BLEND AIR HVAC W/"ATC" TEMP REGULATION	0	0	0
S	I0XAHX	DOME LAMP, INTERIOR	(4) DOME LAMPS - DOOR AND SWITCH ACTIVATED	0	0	0
S	3XAA1X	DASH INDICATOR - LAMP BODY OUT OF POS	DASH MTD, INDICATOR BODY/HOIST UP "BODYBUILDER LAMP"	0	0	0
	786066	FIRE EXTINGUISHER	5LB (ABC RATED/AMEREX) MOUNTED BETWEEN LH SEAT BASE AND DOOR WITH VALVE AIMED REARWARD	9	0	99
S	V8DZ1X	CARBON MONOXIDE DETECTION SYS	WITHOUT CARBON MONOXIDE DETECTION SYSTEM	0	0	0
S	184AA2	FLOOR COVERING	POLYURETHANE FLOOR MAT WITHOUT REMOVABLE INSERTS	0	0	0

			WEIGHT (LB)		LIST PRICE	
CAB INTERIOR (H THRU R)			FRONT	REAR		
		DESCRIPTION				
S	C52082	INSTMNT CLUSTER LANGUAGE	DEFAULT: ENGLISH, SPANISH, FRENCH	0	0	0
S	20XA1X	KEY TYPES FOR DOORS	ALL CHASSIS KEYED AT RANDOM	0	0	0
S	13AA1X	DOOR OPENING OPTIONS	W/O ELECTRONIC KEYLESS ENTRY	0	0	0
S	E3XD1X	FORWARD OVERHEAD STORAGE	(2) STORAGE COMPARTMENTS AND NET RETAINERS W/CENTER MOUNTING FOR CB PROVISIONS	0	0	0
S	1740D4	AUDIO ACCOMMODATION	PREMIUM STEREO, AM/FM, MP3, WEATHER BAND, BLUETOOTH	0	0	0
CA	73AB1X	ANTENNA - RADIO	WARD ANTENNA & CABLE MTG NOT INTERFERE W/ROOF FAIRING - NO RH ANTENNA	0	0	8
	5BXB5X	ANTENNA - CB RADIO	48" ANTENNA LEFT SIDE MIRROR MOUNTED	0	0	56
	0LAZ1X	AUDIO SHUTOFF	W/O AUTO RADIO SHUTOFF OPTION IN REVERSE	0	0	-71
S	1WAB1X	POWER LEADS	POWER LEADS (5-WAY BINDING POSTS FOR CB RADIO) IN HEADER CONSOLE	0	0	0
S	5CXB2X	AUDIO SPEAKER LOCATION	SPEAKER LOCATION, IN DOORS, MIDDLE HIGH SIDE PANEL	0	0	0
S	5JXAIX	COM.RADIO PREP KIT (CB)	CB RADIO MOUNTING REINFORCEMENT IN HEADER CONSOLE	0	0	0
S	21XA1X	AUXILIARY REAR WINDOW	REAR WINDOW (FIXED TYPE)	0	0	0
S	IFXB1X	REAR WALL STORAGE COMPARTMENT	STORAGE POUCH REAR WALL	5	0	0
	784054	REFLECTOR KIT	EMERGENCY REFLECTOR KIT MOUNTED PARALLEL & CENTERED AGAINST BOC	12	5	41

			WEIGHT (LB)		LIST PRICE	
CAB INTERIOR (S THRU Z)			FRONT	REAR		
		DESCRIPTION				
	004034	INTERIOR TRIM LEVELS	PREMIUM PACKAGE, STEEL GRAY (Package 12A)	0	0	712
	196ABQ	SEAT - DRIVER'S	MACK-AIR, HIGH BACK, 4 CHAMBER AIR LUMBAR, BOLSTER, EXTENSION	67	16	564
	MAPC2X	SEAT COVERING - DRIVER'S	DRIVER'S SEAT - STEEL GREY VINYL / CLOTH MIX	0	0	252

TECHNICAL SPECIFICATION (cont.)



CAB INTERIOR (S THRU Z)			DESCRIPTION	WEIGHT (LB)		LIST PRICE
				FRONT	REAR	
	197ABQ	SEAT - PASSENGER'S	MACK-AIR, HIGH BACK, 4 CHAMBER AIR LUMBAR, BOLSTER, EXTENSION	69	14	809
	MAQC2X	SEAT COVERING - PASSENGER'S	PASSENGER'S SEAT - STEEL GREY VINYL / CLOTH MIX	0	0	252
	3PXC1X	SEAT ARMREST	INBOARD MOUNTED ARM REST, DRIVER'S & RIDER'S SEAT	5	3	51
S	592092	SEAT BELT(S)	LAP & SHOULDER (BOTH SEATS) CAB MOUNTED SHOULDER BELT ADJUSTMENT (NOT AVAIL W/EXTENDED RIDER SEAT)	0	0	0
S	2QAA1X	IGNITION TYPE	KEY TYPE	0	0	0
	161021	STEERING WHEEL	2 SPOKE LEATHER GRIP, SATIN ALUMINUM SPOKES, WITH SWITCHES	0	0	29
	WSXAAX	WINDSHIELD TYPE	ONE PIECE WINDSHIELD WITH HEAT	0	0	126
	145AA5	CAB GLASS	HEATED TINTED WINDSHIELD, TINTED SIDE AND REAR WINDOW	0	0	510
	JQXABX	WASHER RESERVOIR POSITION	WINDSHIELD WASHER RESERVOIR INSTALLED BOC	0	0	40
S	148AA3	WINDSHIELD WIPERS	2 SPEED ELECTRIC MOTOR W/INTERMITTENT FEATURE W/HEATED WIPER BLADES	0	0	0

CAB EXTERIOR			DESCRIPTION	WEIGHT (LB)		LIST PRICE
				FRONT	REAR	
S	MCY02Y	HOOD LATCH TYPE & FINISH	STRAP TYPE HOOD LATCH WITH BLACK FINISH	0	0	0
	MCG0AG	EXTERIOR TRIM FINISH AND PACKAGES	GRANITE BRIGHT AIR INTAKE	0	0	24
	400AA5	GRILLE	BRIGHT FINISH GRILLE W/O SURROUND RADIATOR MOUNTED	0	0	47
S	MCD03D	PASSENGER SIDE VISIBILITY OPTIONS	AUXILIARY WINDOW IN RH DOOR	3	0	0
S	2KXB1X	FRONT WHEEL OPENING	FENDER EXTENSIONS BOLTED TO HOOD	5	0	0
	5870B7	GRAB HANDLES	BF EXTERIOR CAB GRAB HANDLES, BLACK GRAB HANDLE RH INTERIOR WINDSHIELD POST	0	0	0
	26XA1X	HOOD HATCH	WITH INSPECTION HATCH FOR SNOWPLOW HOOD LH	0	0	0
	154AC3	HORN - AIR	(2) MACK RECTANGULAR SINGLE TRUMPET, BRIGHT FINISH ALUMINUM W/SNOW SHIELDS	7	0	142
	LXXD1X	HORN - ELECTRICAL	DUAL TONE	5	0	8
	152AA7	MIRRORS - EXTERIOR	AERODYNAMIC MOTO MIRROR PACKAGE: RH/LH MOTORIZED & HEATED WITH TEMP READER	7	0	753
S	153AA2	MIRRORS - CONVEX TYPE CAB DOORS	BRIGHT FINISH, LH & RH, 8" DIAMETER CONVEX	0	0	0
	15H07H	MIRROR - CONVEX HOOD & FENDER	8" ROUND BF FENDER MTD W/SS BRACKETS & ADJ. ARMS R.H. & L.H. (Same as 15H2001)	0	0	199
	157027	SUN VISOR - EXTERIOR	SUN VISOR, EXTERIOR, FIBERGLASS (PAINTED)	12	0	218

AERODYNAMIC DEVICES			DESCRIPTION	WEIGHT (LB)		LIST PRICE
				FRONT	REAR	
S	159AA1	CAB AERODYNAMIC PACKAGES	WITHOUT CAB AERODYNAMIC DEVICES	0	0	0
S	MCM998	FRONT CHASSIS AERODYNAMIC PACKAGE	WITHOUT FRONT AERODYNAMIC FAIRINGS	0	0	0

TECHNICAL SPECIFICATION (cont.)



			WEIGHT (LB)		LIST PRICE	
WHEELS & TIRES		DESCRIPTION	FRONT	REAR		
	900460	TIRES BRAND/TYPE - FRONT	425/65R22.5 L BRIDGESTONE M864 (22800 lbs) (Total for QTY = 2)			1,004
	5312W1	WHEELS - FRONT	22.5x12.25 ALCOA 82462x CLEAN BUFFED ALUMINUM, 5.81" OFFSET, 10 HAND HOLE (Total for QTY = 2)			30
	901A10	TIRES BRAND/TYPE - REAR	11R22.5 H BRIDGESTONE L320 (24020 lbs) (DRIVE ONLY) (Total for QTY = 8)			2,168
	3463E6	WHEELS - REAR	22.5x8.25 ALCOA ULT39x CLEAN BUFFED ALUMINUM, 6.60" OFFSET, 10 HAND HOLE (Total for QTY = 8)			1,472
S	H1EB1X	DRIVE WHEEL STUDS	DRIVE WHEEL STUDS LONGER LENGTH			0
S	15XABX	TIRE INFLATION VALVE	STANDARD VALVE STEMS AND CAPS			0
S	MCH03H	FRONT HUB/WHEEL TRIM	WITHOUT FRONT HUB/WHEEL TRIM			0
S	MCI03I	REAR HUB/WHEEL TRIM	WITHOUT REAR HUB/WHEEL TRIM (Total for QTY = 2)			0
	FIXA1X	HUB/WHEEL ISOLATOR FRONT (CA in PC29 only)	PROTECTIVE NYLON SPACER BETWEEN DISCS WHEEL TO DRUM			22
	FMXA1X	HUB/WHEEL ISOLATOR DRIVE (CA in PC29 only)	PROTECTIVE NYLON SPACER BETWEEN DISCS WHEEL TO DRUM			44
S	80AA1X	WHEEL NUT & FINISH, FRONT	WHEEL NUT BASIC FINISH, FRONT			0
S	3PBA1X	WHEEL NUT FINISH, REAR (CA)	WHEEL NUT BASIC FINISH, REAR			0

			WEIGHT (LB)		LIST PRICE	
COMMUNICATION SYSTEMS		DESCRIPTION	FRONT	REAR		
	3YAB1X	CO-PILOT - DISPLAY FEATURES ACCESS LEVEL	CO-PILOT DISPLAY, FULL DRIVER ACCESS			0
	3RAA1X	FLEET TRIP MANAGEMENT	FLEET TRIP MANAGEMENT DRIVER CONTROL			0
S	M30060	TELEMATIC GATEWAY	TELEMATICS GATEWAY, 4G/LTE AND WLAN SYSTEM WITH DIAGNOSTIC SERVICES			0

			WEIGHT (LB)		LIST PRICE	
ENGINE ELECTRONICS		DESCRIPTION	FRONT	REAR		
S	WOXA1X	OIL PRESSURE, ENGINE SHUTDOWN	OIL PRESSURE, ENGINE SHUTDOWN			0
S	WMXA1X	COOLANT TEMP, ENGINE SHUTDOWN	COOLANT TEMP, ENGINE SHUTDOWN			0
S	K5XA2X	ENGINE PROTECTION SYSTEM	ENGINE PROTECTION (SHUTDOWN)			0
S	K7XH3X	ENGINE IDLE CONTROL	IDLE CONTROL, 650 RPM			0
S	X0AB0X	SMART IDLE ELEVATED IDLE RPM TIME	INCREASE 10 MINUTE MAXIMUM TIME			0
S	M3CA1X	IDLE S/D ABS TAMPER CHECK	IDLE SHUTDOWN ABS TAMPER CHECK, ENABLED			0
S	B1ACAX	IDLE S/D WARNING TIME	30 SEC IDLE S/D WARNING TIME			0
S	A8AALX	IDLE S/D IF WARM-UP TEMP	38C DEG (100F), WARM UP TEMP DELAY			0
S	A4AAEX	IDLE S/D WARM-UP TIMER	5 MIN. WARM UP TIME DELAY			0
S	A6AABX	IDLE S/D IF PTO ACTIVE	ENGINE IDLE SHUTDOWN TIME OVERRIDDEN IF PTO ACTIVE			0
S	B0AAAX	IDLE SHUTDOWN IF POWER > LIMIT	ENG IDLE SHUTDOWN TIME OVERRIDDEN IF TORQUE > THAN LIMIT			0
S	M4CB1X	IDLE S/D OVERRIDE %ENGINE LOAD	IDLE SHUTDOWN OVERRIDE UPTO 20% ENGINE LOAD THRESHOLD			0
S	D2AAFx	AMBIENT TEMP MIN TRESHOLD	AMBIENT TEMP MIN TRESHOLD, 16 DEG C, (60 DEG F)			0

ENGINE ELECTRONICS				WEIGHT (LB)		LIST PRICE
				FRONT	REAR	
S	D3AAEX	AMBIENT TEMP MAX TRESHOLD	AMBIENT TEMP MAX TRESHOLD, 27 DEG C, (80 DEG F)	0	0	0
S	B3ABAX	EL HD THROTTLE,MAX ROAD SPEED	ELECTRONIC HAND THROTTLE, MAX ROAD SPEED, 16 KMH (10 MPH)	0	0	0
	B6ACEX	EL HAND THROTTLE,MAX ENG SPEED	ELECTRONIC HAND THROTTLE, MAX ENGINE SPEED, 2100 RPM	0	0	0
S	B4ADAX	EL HAND THROTTLE,MIN ENG SPEED	ELECTRONIC HAND THROTTLE, MIN ENGINE SPEED, 700 RPM	0	0	0
S	B9AABX	EL HD THROTTLE,SPEED RAMP RATE	ELECTRONIC HAND THROTTLE, SPEED RAMP RATE, 100 RPM/SEC	0	0	0

TRANSMISSION ELECTRONICS				WEIGHT (LB)		LIST PRICE
				FRONT	REAR	
S	M050V5	TRANSMISSION DRIVE MODE PACKAGES, mDRIVE	mDRIVE- ENHANCED CONSTRUCTION - ECON, PERF, & PERF+ DRIVE MODES, AUTO RETURN (premium)	0	0	0
S	6SAA1X	TRANSMISSION KICK-DOWN MODE	MACKCELLERATOR ENABLE	0	0	0
	U7AA1X	TRANSMISSION PROTECTION	TRANS. PROTECTION, ENGINE SHUT DOWN (HIGH TEMP.)	0	0	0
S	779001	TRANSMISSION ELECTRONICS PACKAGE	W/O ELEC TRANS PACKAGE OPTION (all non-Allison transmissions)	0	0	0
	B1EA1X	TRANSM AUTO NEUTRAL ON P-BRAKE	mDRIVE TRANSMISSION PARK BRAKE AUTO NEUTRAL	0	0	0
S	MAV01V	TRANSMISSION ELECTRONIC SHIFTING PROPERTIES	W/O ALLISON FUELSENSE 2.0 PROGRAMMING	0	0	0

VEHICLE ELECTRONICS				WEIGHT (LB)		LIST PRICE
				FRONT	REAR	
S	JCXE6X	ROAD SPEED LIMITER SETTING	105 KM/H ROAD SPEED LIMITER(65 MPH)	0	0	0
	Y3CC5X	PEDAL RSL SETTING	105 KM/H PEDAL ROAD SPEED LIMITER (65MPH)	0	0	0
S	JDXA1X	CRUISE CONTROL	CRUISE CONTROL	0	0	0
S	JFXLLX	CRUISE CONTROL, MAX SPEED	MAX CRUISE, 105 KPH (65 MPH)	0	0	0
S	E3AACX	CRUISE CONTROL MIN SPEED	MIN CRUISE, 32 KPH (20 MPH)	0	0	0
S	E4AAAX	CRUISE RESUME WITH CLUTCH	CRUISE RESUME WITH CLUTCH	0	0	0
S	E5AACX	ENG BRK ENGAGE IN CRUISE	ENG BRK ENGAGE IN CRUISE, 3 MPH, ABOVE SET SPEED	0	0	0
	L1CA1X	PDLO ENGAGE VLS FEATURE	ENABLE POWER DIVIDER LOCK OUT (PDLO) ROAD SPEED LIMIT	0	0	0
S	L2CA1X	PDLO ENGAGED VLS	POWER DIVIDER LOCK OUT (PDLO) ROAD SPEED LIMIT 8KMH (5MPH)	0	0	0
S	A4BAAX	DETECTION SPEED SENSR TMRNG	DETECTION OF SPEED SENSOR TAMPERING, ENABLE	0	0	0
S	8RXAEX	ENG TORQUE LIMIT,SPEED SENSOR	ENG TORQUE LIMITED TO 50%, IF SPEED SENSOR TAMPER DETECTED	0	0	0
S	X3CB1X	DRIVER ID FUNCTION	DRIVER ID FUNCTION, DISABLED	0	0	0
S	0PAZ1X	DR PERFORMANCE PARAMETERS	WITHOUT DRIVER PERFORMANCE PARAMETERS	0	0	0
S	G5AAHX	ENGINE OVERSPEED,ALL COND, LOG	ENGINE OVERSPEED, ALL CONDITIONS, TIME LOG IF ABOVE 2200 RPM	0	0	0
S	G2AAGX	ENGINE OVERSPEED,FUELED, LOG	ENGINE OVERSPEED, FUELED, TIME LOG IF ABOVE 2100 RPM	0	0	0

**TECHNICAL SPECIFICATION (cont.)**

				WEIGHT (LB)		LIST PRICE
VEHICLE ELECTRONICS		DESCRIPTION		FRONT	REAR	
S	G4AAUX	VEHICLE OVERSPEED, ALL COND, LOG	VEHICLE OVERSPEED, ALL COND, TIME LOG IF ABOVE 75MPH (121KMH)	0	0	0
S	G3AAPX	VEHICLE OVERSPEED, FUELED, LOG	VEHICLE OVERSPEED, FUELED, TIME LOG IF ABOVE 70MPH (113KMH)	0	0	0
S	G1AABX	ENGINE IDLE DELAY TO LOG	ENGINE IDLE DELAY TO START LOG, 2 MIN	0	0	0
S	W9A01X	PERIODIC TRIP LOG DAY OF MONTH	PERIODIC TRIP LOG, DAY 1 OF THE MONTH	0	0	0

				WEIGHT (LB)		LIST PRICE
PTO ELECTRONICS		DESCRIPTION		FRONT	REAR	
S	Y9CR1X	TRANS PTO1 SPLITTER RANGE	PTO1 FOR SPLITTER RANGE - KEYPAD REMOTE CONTROLLED	0	0	0
S	Z1CR1X	TRANS PTO2 SPLITTER RANGE	PTO2 FOR SPLITTER RANGE - KEYPAD REMOTE CONTROLLED	0	0	0
S	F3AAEX	PTO1 SINGLE SPEED CONTROL RPM.	PTO 1ST, SINGLE SPEED SETTING, 1000 RPM	0	0	0
S	F5AABX	PTO 1ST, MAX ROAD SPEED	1ST PTO, MAX ROAD SPEED, 10 MPH (16 KPH)	0	0	0
S	F6AABX	PTO 1ST, SPEED RAMP RATE	PTO 1ST, SPEED RAMP RATE 100 RPM/SEC	0	0	0
S	F7AAPX	PTO 1ST, MAX ENGINE SPEED	PTO 1ST, MAX ENGINE SPEED, 2100 RPM	0	0	0
S	F8AAGX	PTO 1ST, ROAD SPEED LIMIT	PTO 1ST, ROAD SPEED LIMIT, 97 KMH (60 MPH)	0	0	0
S	F9AABX	PTO 1ST, MINIMUM ENGINE SPEED	PTO 1ST, MINIMUM ENGINE SPEED, 600 RPM	0	0	0
S	H6AAEX	PTO 2ND, SINGLE SPEED SETTING	PTO 2ND, SINGLE SPEED SETTING, 1000 RPM	0	0	0
S	H0AABX	PTO 2ND, MAX ROAD SPEED	2ND PTO, MAX ROAD SPEED, 10 MPH (16 KPH)	0	0	0
S	G9AABX	PTO 2ND, SPEED RAMP RATE	PTO 2ND, SPEED RAMP RATE 100 RPM/SEC	0	0	0
S	H7AANX	PTO 2ND, MAX ENGINE SPEED	PTO 2ND, MAX ENGINE SPEED, 2100 RPM	0	0	0
S	H5AAGX	PTO 2ND, ROAD SPEED LIMIT	PTO 2ND, ROAD SPEED LIMIT, 97 KMH (60 MPH)	0	0	0
S	G8AABX	PTO 2ND, MINIMUM ENGINE SPEED	PTO 2ND, MINIMUM ENGINE SPEED, 600 RPM	0	0	0

				WEIGHT (LB)		LIST PRICE
PAINT		DESCRIPTION		FRONT	REAR	
S	950AD0	PAINT DESIGN	SINGLE COLOR	0	0	0
S	924014	PAINT TYPE	SOLID PAINT	0	0	0
S	944AA7	PAINT COLOR - FIRST COLOR	MACK WHITE; P9188	0	0	0
S	945998	PAINT COLOR - SECOND COLOR	NO SECOND TRUCK COLOR PROVIDED; NO COLOR	0	0	0
S	946998	PAINT COLOR - THIRD COLOR	NO THIRD TRUCK COLOR PROVIDED; NO COLOR	0	0	0
S	996AA3	PAINT - CAB PAINT SYSTEM	PAINT - CAB, URETHANE CLEAR COAT	0	0	0
S	MPB944	CAB COLOR	SAME AS FIRST COLOR - CAB	0	0	0
S	MPD944	HOOD COLOR	SAME AS FIRST COLOR - HOOD	0	0	0
	966944	SUN VISOR COLOR	SAME AS FIRST COLOR - SUN VISOR	0	0	57
S	MPC998	SLEEPER ROOF COLOR	WITHOUT SLEEPER ROOF COLOR	0	0	0
S	MPA998	ROOF FAIRING COLOR	WITHOUT ROOF FAIRING	0	0	0
S	951AA6	CHASSIS RUNNING GEAR	MACK BLACK (URETHANE)	0	0	0
S	958018	BUMPER	PAINT BUMPER SAME COLOR AS CHASSIS RUNNING GEAR	0	0	0
S	959019	FUEL TANK - ***NO INVENTED VARIANTS ALLOWED in the FUEL TANK PAINT FAMILY***	W/O OPTIONAL FUEL TANK PAINT	0	0	0

PAINT	DESCRIPTION	WEIGHT (LB)		LIST PRICE
		FRONT	REAR	
S 962032	HUBS & DRUMS-FRONT SAME AS CHASSIS RUNNING GEAR	0	0	0
S 963033	HUBS & DRUMS-REAR SAME AS CHASSIS RUNNING GEAR	0	0	0

CALCULATED CODES - KAX	DESCRIPTION	WEIGHT (LB)		LIST PRICE
		FRONT	REAR	
S 9JXA1X	PROPCALC SELECTION YES, THE ORDER MUST BE CALCULATED	0	0	0

BASE WARRANTY & PURCHASED COVERAGES	DESCRIPTION	WEIGHT (LB)		LIST PRICE
		FRONT	REAR	
S 898003	VEHICLE WARRANTY TYPE HEAVY DUTY WARRANTY CLASSIFICATION	0	0	0
S M50030	BASIC CHASSIS COVERAGE HEAVY DUTY STANDARD BASE COVERAGE 12 MONTHS/100,000 MILES (161,000 KM)	0	0	0
REQUIRED M8302T	EMISSION - SURCHARGE CARB + EPA for Mack MP7 / MP8 Diesel	0	0	2,100
OPTIONAL M51EH1	ENGINE WARRANTY ENG PLAN 2: 60 MO/400K MI-EXT ENGINE COVERAGE MP7/MP8 >460HP	0	0	4,924
S M52022	EMISSION COMPONENT COVERAGE US and CANADA EQUIPPED VEHICLE EMISSION COMPONENTS COVERAGE 60 MONTHS/100,000 MILES (161,000 KM)	0	0	0
OPTIONAL M53065	ENGINE AFTERTREATMENT SYSTEM CARB - EATS: 60 MO/400K MI-ENGINE AFTERTREATMENT <460	0	0	174
S M54104	TRANSMISSION WARRANTY 36 MONTHS: STANDARD mDRIVE HD TRANSMISSIONS HEAVY DUTY WARRANTY	0	0	0
OPTIONAL M71061	mDRIVE CLUTCH PROTECTION PLAN mDRIVE HD CLUTCH 60/250K MI, HEAVY DUTY PROTECTION PLAN	0	0	782
S M550G7	CARRIER & AXLE HOUSING WARRANTY STANDARD MACK HEAVY DUTY COVERAGE 60 MONTHS / 500,000 (804,672 KM)	0	0	0
S M56026	AIR CONDITIONING WARRANTY AIR CONDITIONING STANDARD COVERAGE (Sealed System Only) 12 MONTHS UNLIMITED MILEAGE	0	0	0
S M57027	CHASSIS TOWING WARRANTY STANDARD NORMAL / HEAVY DUTY CHASSIS TOWING 90 DAYS OR 5,000 MILES	0	0	0
OPTIONAL M580E8	ENGINE TOWING WARRANTY ENGINE TOWING 60 MO/250K MILES (MACK ENGINES)	0	0	800
INCLUDED M690C9	GUARDDOG CONNECT BUNDLE 60 MONTH - GUARDDOG CONNECT WITH MACK OTA (with ASIST and Mack OneCall)	0	0	0
S M78010	PREPAID API WITHOUT PREPAID API	0	0	0
S M67017	PREMIUM MAINTENANCE - CHASSIS LUBE AND INSPECTION W/O PREMIUM MAINTENANCE - CHASSIS LUBE AND INSPECTION COVERAGE	0	0	0

UNPUBLISHED OPTIONS FOR DOT UNITS				WEIGHT (LB)		LIST PRICE
ADDITIONAL OPTIONS (NonApproved)	DESCRIPTION	FRONT	REAR			
CA 8269019	HYDRAULIC PUMP F1-81R PARKER PUMP/REAR OF ENG/INC 8 QT TEMP RESERVOIR	0	0	0		
CA 1489010	WINDSHIELD WIPERS 2 SPEED ELECTRIC MOTOR W/INTERMITTENT FEATURE - EVERBLADE ELECT HTD. WIPERBLADES W/SEP SWITCH&LIGHT	0	0	0		

ADDITIONAL ENGINEERING (NonApproved)				WEIGHT (LB)		LIST PRICE
DESCRIPTION	FRONT	REAR				
CA 1	0	0	0			

---

FRONT / REAR AXLE WEIGHTS (LB)

10051 8823

TOTAL WEIGHT (LB)

18,874

---

PRICELIST DATE

QUOTATION

DATE

PAGE

CUSTOMER NAME

DEALER NAME

20220103

CONW2021000450A544

8/23/2021

14 of 21

ULYSSES HIGHWAY DEPARTMENT

BEAM MACK SALES & SERVICE, INC.



# PRICING SUMMARY

## GRANITE 64FR

### VEHICLE PRICE

\$139,398.00

### EXTERNAL LOCALS

VIKING EQUIPMENT QUOTE #1503

\$98,578.65

### TOTAL VEHICLE PRICE

\$237,976.65

### SOFT OFFERS AND WARRANTY

ENG PLAN 2: 60 MO/400K MI-EXT ENGINE COVERAGE MP7/MP8 >460HP

CARB - EATS: 60 MO/400K MI-ENGINE AFTERTREATMENT <460

ENGINE TOWING 60 MO/250K MILES (MACK ENGINES)

mDRIVE HD CLUTCH 60/250K MI, HEAVY DUTY PROTECTION PLAN

CARB + EPA for Mack MP7 / MP8 Diesel REQUIRED FOR 2023 MODEL YEAR GHG22 LEVEL CARB EMISSIONS

OPTIONAL EXTENDED  
WARRANTY ITEMS  
MAY BE PURCHASED  
UP TO 9 MONTHS  
POST IN SERVICE DATE

\$4,924.00

\$174.00

\$800.00

\$782.00

\$2,100.00

### TOTAL SOFT OFFERS AND WARRANTY

\$87,780.00

### TAX SUMMARY

#### AMT. SUBJECT TO TAX

FET (12%)

N/A

\$0.00

Tire Tax Credit

N/A

\$(309.78)

### TOTAL TAX

\$(309.78)

### TOTAL SELLING PRICE (PER UNIT)

\$246,446.87

PRICE INCLUDES EXTENDED FACTORY WARRANTY ITEMS

*Gary P. Lantz*

8/23/2021

ULYSSES HIGHWAY DEPARTMENT

DATE

BEAM MACK SALES & SERVICE, INC.

DATE



## VEHICLE SPECIFICATION/CALCULATED PERFORMANCE SUMMARY

Description	Sales Code	Dwg. Ref.	Length	UOM
Front Frame Extension	N/A	FE	20.0	INCHES
Bumper to Front Axle	N/A	BA	29.0	INCHES
Wheelbase	N/A	WB	230.1	INCHES
Rear Overhang	N/A	OH	87.0	INCHES
Overall Length	N/A	OL	366.1	INCHES
Bumper to Back of Cab	N/A	BBC	116.5	INCHES
Eff. Bumper to Back of Cab	N/A	EBBC	141.0	INCHES
Eff. Cab to Rear Axle	N/A	ECA	138.1	INCHES
Eff. Front Axle to Back of Cab	N/A	EAC	92.0	INCHES
Eff. Cab to End of Frame	N/A	ECEF	225.1	INCHES
Unladen 5th Wheel Height	E5BZ1X	5W	0.0	INCHES
Unladen Frame Height	N/A	FH	44.1	INCHES
Cab Height	N/A	CH	70.9	INCHES
Overall Height	N/A	OVH	118.1	INCHES
Driver CG	N/A	DCG	70.9	INCHES
54" AXLE SPACING (BOGIE WHEELBASE)	GWXDGX	BS	53.9	INCHES
Second Front Axle Spacing	RHXZ1X	SFAS	0.0	INCHES

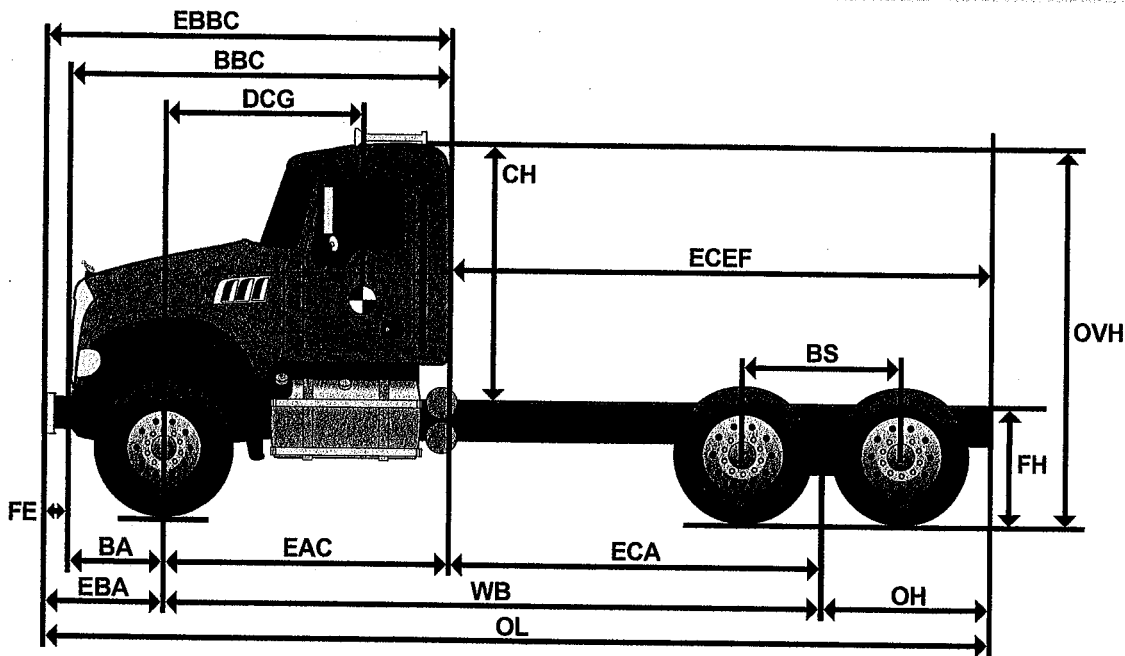

## VEHICLE SPECIFICATION/CALCULATED PERFORMANCE SUMMARY

Description	Sales Code	Dwg Ref	Left Value (in)	Right Value (in)
Wheelbase	N/A	WB	230.1	230.1
Available Rail Space Right	N/A	ARSR	N/A	98.5
Available Rail Space Left	N/A	ARSL	91.9	N/A
Eff. Front Axle to Back of Cab	N/A	REF	92.0	92.0
Front Axle To Fender	CDX23X	N/A	35.4	35.4
Cleartech One Unit	DPF04F	N/A	0.0	48.0
Battery Box	393AA2	N/A	15.0	0.0
72 GALLON (275 L) 26" ALUMINUM, SLEEVED D-SHAPED / W/O RH FUEL TANK	288AF3 / 290AA1	N/A	32.2	0.0
Ad-Blue Tank	DF10P1	N/A	7.5	0.0
Drive Tire Radius	901A10	N/A	21.2	21.2

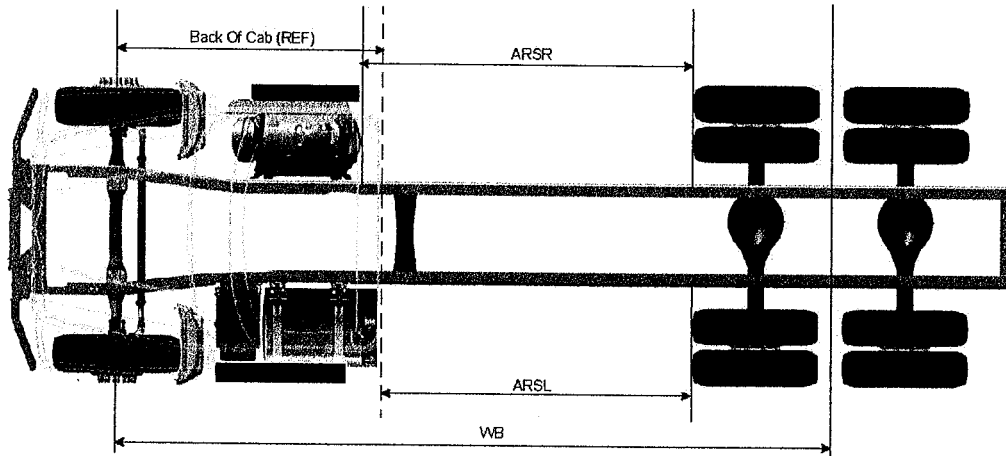

*Top View image is intended for illustration purposes only and is not presented to scale. Wheelbase, Axle Spacing and After frame are not shown as specified, but are a representation. Customer Adaptation (CA) options and relocated components are not represented in these images. Most CA options impact the variation of the image, thus an image may not populate. Calculations are approximate to a tolerance of  $\pm 4$  inches due to component mounting variation. Certain chassis component options are NOT represented in the Top View image, such as, but not exclusive to, Front Frame Extensions, Fuel Water Separators, Air Dryers, PTOs, Fifth Wheels, Chassis Fairings, Toolboxes, Trailer Connections. For further information on these items and their respective locations on your specification, please refer to the data sheets associated with those items in the configurator.*

## VEHICLE SPECIFICATION/CALCULATED PERFORMANCE SUMMARY

Description	Sales Code	Dwg Ref	Rear		UOM
			Unladen	Laden	
Requested Fifth Wheel Height	E5BZ1X		0.0	0.0	INCHES
Tire Radius	901AI0	A	21.2	19.8	INCHES
Suspension Height	186AC7	B	11.1	9.9	INCHES
Frame Depth	YBXGAX	C	11.8	11.8	INCHES
Closest Available Fifth Wheel Leg Height	N/A	D	0.0	0.0	INCHES
Total Height	N/A	E	44.1	41.5	INCHES

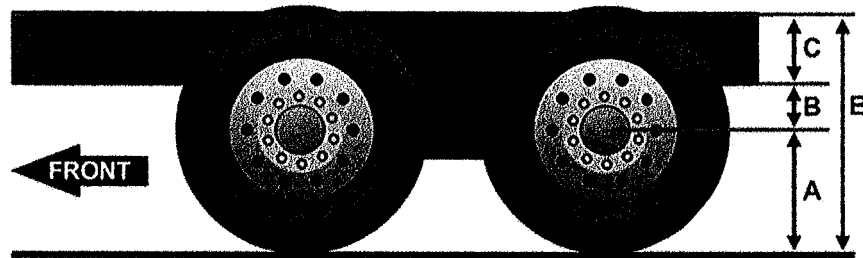

## VEHICLE SPECIFICATION/CALCULATED PERFORMANCE SUMMARY

Description	Sales Code	Dwg Ref	Length	UOM
SAE Turning Radius	N/A	A*	36.7	FEET
Adjusted Turning Radius	N/A	A	41.2	FEET
Curb-to-Curb Diameter	N/A	B	83.8	FEET
Wall-to-Wall Diameter	N/A	C	89.8	FEET

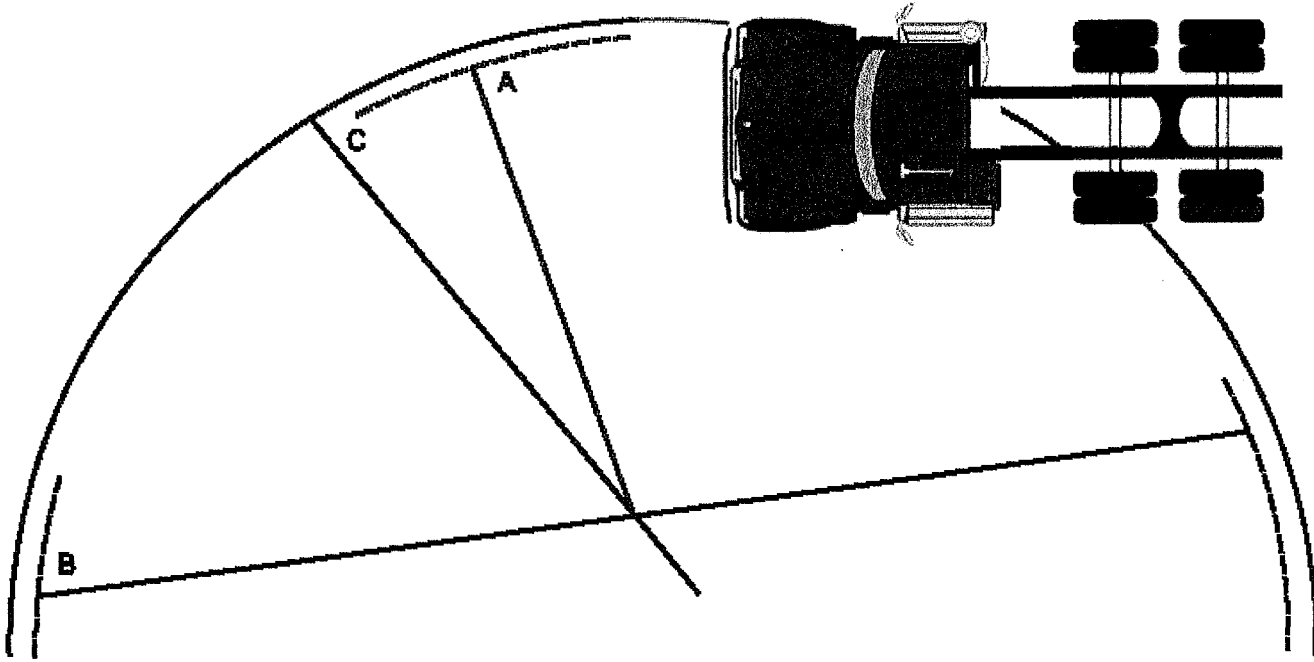

Tests have shown that the true location of the turning center is further to the rear than midway between drive axle sets (where applicable)

The actual location of the turning center depends on:

- Whether the drive tire equipment is single or dual.
- The overall load distribution for the vehicle (front/rear, between drive axles) in a loaded condition
- Manufacturing tolerances within the steering components

Inputs Required	Inputs	UOM
Driver Weight	201	LB
Total Body Length	16.4	FEET
Body Tare Weight	3501	LB
Front of Body to Body CG	96.0	INCHES
Additional Clearance from Back of Exhaust to Front of Body	6.0	INCHES

### VEHICLE SPECIFICATION SUMMARY

Description	Description	Dwg. Ref.	Length	UOM
Bumper to Front Axle	N/A	BA	29.0	INCHES
Wheelbase	N/A	WB	230.1	INCHES
Rear Overhang	N/A	OH	87.0	INCHES
Bumper to Back of Cab	N/A	BBC	116.5	INCHES
BOC Exhaust Space	130AD7	N/A	0.0	INCHES
Driver CG from Front Axle	N/A	DCG	70.9	INCHES
First Pusher Axle Spacing			0.0	INCHES

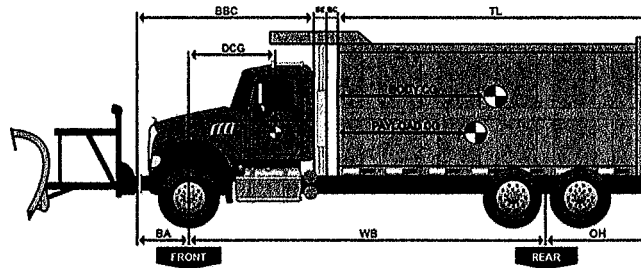

### CALCULATED PERFORMANCE SUMMARY

Tare Weights	Front Axle	Rear Axle (s)	Total	UOM
Chassis	10051	8823	18874	LB
Driver	139	62	201	LB
Fuel	350	143	492	LB
Body/Trailer	617	2884	3501	LB
<b>Total Tare</b>	<b>11156</b>	<b>11912</b>	<b>23067</b>	<b>LB</b>
Payloads				
First Body Payload	8060	37675	45734	LB
Total - Lift Axles Down	19215	49586	68801	LB
GAWR	22801	46001	110000	LB

## VEHICLE SPECIFICATION/CALCULATED PERFORMANCE SUMMARY

Sub-Category	Sales Code	Sales Code Description	Value	UOM
Front Axle	240AA5	23000# (10400 KG) MACK FXL23 WIDE PIVOT CENTER STRAIGHT SPINDLE/UNITIZED BEARINGS	23000	LB
Front Suspension	244124	MACK MULTILEAF 23000# (10400 KG) GROUND LOAD RATING, RIGHT SPRING BIAS	23000	LB
Front Tires	900460	425/65R22.5 L BRIDGESTONE M864 (22800 lbs)	22801	LB
Front Wheels	5312W1	22.5x12.25 ALCOA 82462x CLEAN BUFFED ALUMINUM, 5.81" OFFSET, 10 HAND HOLE	24600	LB
		Front GAWR	22801	LB
Rear Axle	268AA9	46000# (20900kg) MACK S462R CAST DUCTILE HOUSING	46001	LB
Rear Suspension	186AC7	MACK mRIDE 46 PARABOLIC 3-LEAF, 46,000 lb	46001	LB
Rear Tires	901A10	11R22.5 H BRIDGESTONE L320 (24020 lbs) (DRIVE ONLY)	48041	LB
Rear Wheels	3463E6	22.5x8.25 ALCOA ULT39x CLEAN BUFFED ALUMINUM, 6.60" OFFSET, 10 HAND HOLE	59199	LB
		Rear GAWR	46001	LB
		Truck GVWR	68801	LB
		Gross Combination Weight Rating	110000	LB
		Tax Value GVWR (USA FET Only)	69000	LB

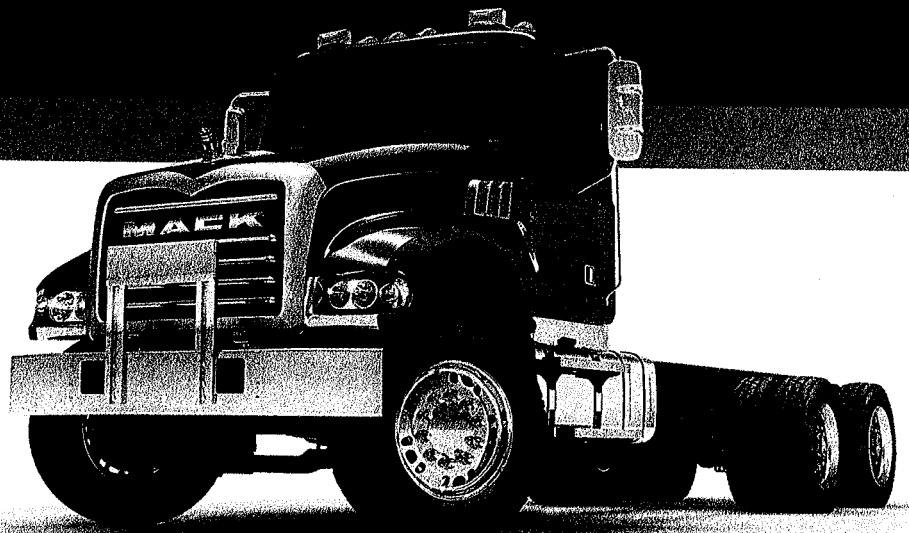



**Cives Corporation, dba  
Viking Cives (USA)**  
14331 Mill Street  
Harrisville, NY 13648  
Phone: (315) 543-2321  
Fax: (315) 543-2366  
www.vikingcives.com

**QUOTATION**

Quote ID: Quoteld

Page 1 of 1

ONONDAGA 2013  
Catalog

**Customer:** BEAM MACK SALES & SERVICE  
**Contact:**  
**Address:** 3050 LAKE ROAD  
HORSEHEADS NY 14845  
  
**Phone:** 607-733-4606  
**Fax:**  
**Attn:**

**Quote Number:** 1503  
**Quote Date:** 8/20/2021  
**Quote valid until:** 9/20/2021  
**For:** Ulysses T-O  
**Terms:** Net 30 days  
**Salesperson:** MATT GIBSON  
**FOB:** Destination

QUANTITY	DESCRIPTION	UNIT PRICE	AMOUNT
	PUMP SUPPLIED BY VOLVO		
	HITCH FOR FACTORY MOUNTS		
1	Hitches with mtg. bolts & nuts, pins (P10)		
1	S10500F - Custom Hitch Plow & Wing Mount-Power Tilt (incl. yoke)		
1	S11010 - 4" x 10" DA Cylinder (cannot be used with Husting Hitches)		
1	S12000 - No Pump Bracket		
1	S13600 - UQH Truck Half		
1	S14001 - LIFT GROUP - THREE GRAB		
1	S15101F - Quick Disconnects for Lift Cylinder, stainless steel		
	HYDRAULICS FOR FACTORY MOUNTS		
1	S22030F - 40 Gallon (RH) Cabinet Mount (for H600 & H700 Series Rear Mast)		
1	S22117F - Low Oil Sensor (for cabinet tank)		
1	S22120 - Return Line Manifold		
1	S22111 - Hyd Oil Line Shut Off (each) 2" (must use with load sense systems)		
1	S24210F - Cab Control, Two Handle Floor Mount- air operated		
1	S24240F - Cab Control, Four Handle Pedestal Mount-air operated		
1	S24280F - For units with Two Air Cab Controls		
1	S20001F - CUSTOMIZED HYDRAULIC PACKAGE		
	REXROTH HYDRAULIC PACKAGE TO INCLUDE THE FOLLOWING:		
	8 SECTION M4 VALVE (2, 1 SA, 3 DA, 2 SA)		
	PUMP BEING SUPPLIED BY TRUCK MANUFACTUER (MACK)		
	2-1/2" SUCTION FLANGE		
	LOW OIL SHUT DOWN BLOCK		
	LOW OIL SHUT DOWN CONTROL		
	CS 520 CONTROLLER AND WIRING KIT		
	PRESSURE FLANGE		
1	S26430SF - Hose Kit - Full Mount with SS tubing under truck		
	SPREADER CONTROL SYSTEM		
1	S25016F - Controller Plumbed to Rear of Truck Chassis (includes Snap-Tite quick disconnects, both halves)		





Cives Corporation, dba  
 Viking Cives (USA)  
 14331 Mill Street  
 Harrisville, NY 13648  
 Phone: (315) 543-2321  
 Fax: (315) 543-2366  
 www.vikingcives.com

**QUOTATION**

Quote ID: Quoteld

Page 2 of 1

ONONDAGA 2013  
 Catalog

SS QUICK DISCONNECTS AND SS LINES

FRONT MAST FOR FACTORY MOUNTS

- 1 S30700F - FH33 Hydraulic Assembly w/mtg. brk't (3 x 33 cyl.)
- 1 S33300F - Full Trip Hinge (not to be used with trip edge wing)
- 1 S34001F - Quick Disconnects for Front Wing Cylinder, stainless steel (1 per front mast)

REAR MAST FOR FACTORY MOUNTS

- 1 S40517F - HC109650H (RH) Rear Mast Assembly (includes poly cyl and valve box covers)
- 1 S40320F - 5/8" wire rope cable (for use with Hydraulic (FH - FAH) Front Mast)

Viking Side Dump  
 86" Inside Width, 98" Outside  
 Standard 3/16" Corten Steel Construction  
 1/4" Hardox 450 Tipper Floor  
 25:1 Wormgear Gearbox  
 Double Acting Tailgate  
 Solid Curb Sidewall  
 Ladder Front Left  
 Bar Flights Every 2nd Link  
 SS Tipper Hinge & Pin  
 Remote Grease

- 1 ON10003 - PL1415SD(12.4/15.5) 40" Side Height with 55" Tailgate height

CUT FRAME AT AN ANGLE - CUSTOMER WILL BE INSTALL OWN CHIPPER BAR

- 1 ON10004 - Side Tilt Indicator
- 1 ON10007 - Asphalt Apron
- 1 ON10019 - Bar Flights every link
- 14 ON10154 - 304L Stainless Steel Body Construction (Per Foot)

ACCESSORIES

- 1 S70003F - Plow Lights LED (for use with one way plows) - ABL
- 1 S70100F - Wing or Auxiliary Light (Truck Lite)
- 1 S70110F - Sander Light (Truck Lite)
- 1 S70121F - LED Lights Stop/Tail/Turn - back of body (pair)
- 3 S70388F - LED Strobe Amber Flashing Lights - back of body (pair)

1 SET BACK OF BODY  
 1 SET FRONT CABSHIELD  
 1 SET SIDE CABSHIELD

- 1 S70386F - LED Back Up Lights - back of body (pair)
- 1 S70134F - LED Marker Lights (4 red)
- 1 S70021F - Spotlight w/ wireless remote, magnetic base (Go Light)
- 1 S89333F - 9016LED 16" LIGHT
- 1 S70147F - Poly Fenders for Tandem Axle Trucks



**Cives Corporation, dba  
Viking Cives (USA)**  
14331 Mill Street  
Harrisville, NY 13648  
Phone: (315) 543-2321  
Fax: (315) 543-2366  
[www.vikingcives.com](http://www.vikingcives.com)

**QUOTATION**

Quote ID: Quoteld

Page 3 of 1

ONONDAGA 2013  
Catalog

1	ROLL-RITE ELECTRIC TARP SYSTEM		
1	GS71105F - ROLL-RITE 6400 Aluminum Tarp System, external mount 4-spring pivot set, 92" tarp spool		
1	GS71117 - ROLL-RITE 8318 Heavy Duty Asphalt Tarp, 18 ft.		
	<b>FACTORY INTALLATION</b>		
1	S79010F - Factory Install - Full Mount		
1	S79100F - Factory Install - Plow Lights		
1	S79110F - Factory Install - Wing Lights or Driving Lights or TT Light Stanchion		
2	S79115F - Factory Install - Sander Light or SpotLight		
1	S79117F - Factory Install - Revolving Light or Strobe Light		
1	S79150F - Factory Install - extra valve section (per each section)		
1	S79180F - Factory Install - Electric Spreader control (piped to rear of cab)		
1	S79210F - Factory Install - Dump Body - Combination Style (front or rear discharge)		
1	S79310F - Factory Install - Tarp System, semi-automatic or electric		
	<b>ONE WAY PLOW, HIGH SPEED COMPRESSION SPRING</b>		
1	S50131 - 3564HSE9 Moldboard (RH)		
1	S50200 - Fabricated Nose Piece - 1/2" thick (cannot use with 60 deg. mold shoe)		
1	S52141 - BLADE CARBIDE 12" SABRE 11 FT		
1	S50502 - Compression Spring One Way Pushframe (includes inner arm)		
1	S50526 - UQH Hitch Female (plow half)		
1	S50550 - #65 Adj. Pushframe Shoes, Alloy (pair)		
2	S54502 - SHOE MOLDBOARD 60 DEG OW CARBIDE-SABRE		
1	S50650 - Rubber Deflector Option 12" wide - for OW3153TE9		
1	S50685 - Plow Markers for OW3153TE9 moldboards, flexible fluorescent orange,		
	<b>WING</b>		
1	S60040 - 144WHD RH WING WELDMENT		
2	S54501 - SHOE MOLDBOARD 10 DEG CARBIDE SGL-SABRE		
1	S52141 - BLADE CARBIDE 12" SABRE 11 FT		
1	S61071 - Full Trip HD Arms (cushion spring lower)		
		<b>Quote Total:</b>	<b>\$142,328.00</b>
		30.90% <b>Discount :</b>	<b>(\$43,979.35)</b>
		<b>Total Cost For Equipment:</b>	<b>\$98,348.65</b>
	<b>Delivery to Region 1</b>	<b>Charges</b>	<b>230</b>
		<b>Total Due</b>	<b>\$98,578.65</b>

\*\*\*\*\*



Cives Corporation, dba  
 Viking Cives (USA)  
 14331 Mill Street  
 Harrisville, NY 13648  
 Phone: (315) 543-2321  
 Fax: (315) 543-2366  
 www.vikingcives.com

**QUOTATION**

Quote ID: Quoteld

Page 4 of 1

ONONDAGA 2013  
 Catalog

The following options may be added:

QUANTITY	DESCRIPTION	PRICE EACH	AMOUNT

Customer must fill out the information below before the order can be processed...

Accepted by:	
Date:	
P.O. number:	

The price and terms on this quotation are not subject to verbal changes or other agreements unless approved in writing by the Home Office of the Seller. All quotations and agreements are contingent upon strikes, accidents, fires, availability of material and all other causes beyond our control. Prices are based on costs and conditions existing on date of quotation and are subject to change by the Seller before final acceptance.

- ◆ Typographical and stenographic errors subject to corrections. Purchaser agrees to accept either overage or shortage not in excess of ten percent to be charged pro-rata. Purchaser assumes liability for patent and copyright infringement when goods are made to Purchaser's specifications. When quotation specifies material to be furnished by the purchaser, ample allowance must be made for reasonable spoilage and material must be of suitable quality to facilitate efficient production.
- ◆ Conditions not specifically stated herein shall be governed by the established trade customs. Terms inconsistent with those stated herein which may appear on Purchaser's formal order will not be binding on the Seller.
- ◆ Unless otherwise stated, Installation charges do not include modifications to exhaust systems, cab protectors or bumpers.



Baystone Government Finance

August 4, 2021

# FORMAL PROPOSAL

**OBLIGOR:** TOWN OF ULYSSES, NY

- ✓ This is an Installment Purchase Contract. No residual value.
- ✓ Fixed interest rate for the three (3) year, and five (5) year terms.

**EQUIPMENT:** ONE (1) 2021 MACK GRANITE 64FR

**OPTION 1**

Acquisition Cost:	\$250,000.00	Term:	Three (3) years	First Payment Due:	One Year from Close
Document Fee:	\$ 395.00	Payment Mode:	Annual in Arrears	Payment Amount:	\$88,301.07
Trade In:	\$ 0.00	Interest Rate:	2.870%		
Principal Balance:	\$250,395.00	Rate Factor:	0.352647		

**OPTION 2**

Acquisition Cost:	\$250,000.00	Term:	Five (5) years	First Payment Due:	One Year from Close
Document Fee:	\$ 395.00	Payment Mode:	Annual in Arrears	Payment Amount:	\$54,503.29
Trade In:	\$ 0.00	Interest Rate:	2.890%		
Principal Balance:	\$250,395.00	Rate Factor:	0.217669		

**OPTION 3**

Acquisition Cost:	\$250,000.00	Term:	Three (3) years	First Payment Due:	At Closing
Document Fee:	\$ 395.00	Payment Mode:	Annual in Advance	Payment Amount:	\$85,796.59
Trade In:	\$ 0.00	Interest Rate:	2.820%		
Principal Balance:	\$250,395.00	Rate Factor:	0.342645		

**OPTION 4**

Acquisition Cost:	\$250,000.00	Term:	Five (5) years	First Payment Due:	At Closing
Document Fee:	\$ 395.00	Payment Mode:	Annual in Advance	Payment Amount:	\$52,912.36
Trade In:	\$ 0.00	Interest Rate:	2.830%		
Principal Balance:	\$250,395.00	Rate Factor:	0.211316		

- **This is a proposal only and is not a commitment to finance. This proposal is subject to credit review and approval and proper execution of mutually acceptable documentation.**
- Failure to consummate this transaction once credit approval is granted and the documents are drafted and delivered to Obligor will result in a documentation fee being assessed to the Obligor.
- This transaction must be credit approved, all documents properly executed and returned to Baystone Government Finance and the transaction funded on ALL proposals on or before September 4, 2021. If funding does not occur within that time-frame, or there is a change of circumstance which adversely affects the expectations, rights, or security of Obligee or its assignees, then Obligee or its assignees reserve the right to adjust and determine a new interest rate factor and payment amount, or withdraw this proposal in its entirety.
- This transaction must be designated as tax-exempt under Section 103 of the Internal Revenue Code of 1986 as amended.
- **OBLIGOR'S TOTAL AMOUNT OF TAX-EXEMPT DEBT TO BE ISSUED IN THIS CALENDAR YEAR WILL NOT EXCEED THE \$10,000,000 LIMIT, OR THE INTEREST RATE IS SUBJECT TO CHANGE.**
- **Neither KS StateBank nor Baystone Government Finance is acting as an advisor to the municipal entity/obligated person and neither owes a fiduciary duty pursuant to Section 15B of the Exchange Act of 1934**

**BAYSTONE GOVERNMENT FINANCE**

**TOWN OF ULYSSES, NY**

Aaron Lindsten ~ alindsten@ksstate.bank  
Assistant Vice President

Signature

Title

Date

1010 Westloop Place, Manhattan, KS 66502  
800.752.3562 ~ Fax: 785.537.4806